

Test-bench for the Characterization of MicroMegas Modules for the T2K ND280 TPC

M.Di Marco for the T2K TPC groups.

Université de Genève, 24 Quai E-Ansermet, 1211 Genève, Switzerland.

E-mail: Marie.Di.Marco@physics.unige.ch

Abstract. This proceeding reports on the design and construction of a test-bench to characterize the readout of the T2K ND280 TPC on a pad-per-pad basis. This procedure is an essential part of the ND280 calibration program as it will ensure that the criteria for the momentum and $\frac{dE}{dx}$ resolutions are met.

1. Introduction

T2K is a long baseline neutrino oscillation experiment aiming at the discovery of the $\nu_\mu \rightarrow \nu_e$ appearance with a factor 20 of improvement in sensitivity over past experiments. A high intensity proton beam from the JPARC 50 GeV synchrotron produces a pion decay neutrino beam aimed with a 2.5 degree off-axis angle to the Super-Kamiokande detector. The flux, spectrum and cross sections of the neutrinos have to be measured before they oscillate. This is achieved by the near detector, located 280m away from the source. ND280 uses the UA1 magnet operated with a magnetic field of 0.2 T, in which sits a tracker composed of 3 time projection chambers (TPC's) interlayered with 2 fine grained detectors (FGD's). The ν energy peaks at 750 MeV/c, and most interactions in the FGD's are of CCQE type. The $1 \times 2.5 \times 2.5$ m³ TPC's will measure the 3-momentum of the charged particles, readout by 12 MicroMegas (micropattern gas detectors) each (see fig.1). See [1] for more details.

1.1. Need for a highly segmented readout.

In its first phase, T2K will measure ν_μ disappearance to measure Δm_{23}^2 and $\sin^2 \theta_{23}$ with high precision. To reach this goal, the momentum resolution needs to be better than 10% at 1 GeV, which is the limit given by the Fermi motion of the target nuclei. To distinguish electrons from muons at 3σ , a resolution of 10% on $\frac{dE}{dx}$ at that energy is needed. Because of the moderate magnetic field of 0.2T provided by the UA1 magnet, the curvature of the tracks is also moderate, and needs to be compensated by an optimal space point resolution. For that, a high segmentation of the readout becomes necessary, and because of the space constraints imposed by the fact that the tracker has to sit within the UA1 magnet, the readout has to be compact. In the ND280 configuration, the tracks are perpendicular to the drift field (see fig.1), therefore strips cannot be used, and the readout has to be made out of a padplane.

For these design criteria of compactness and high segmentation, the MicroMegas technology has been chosen for the readout of the T2K ND280 TPC.

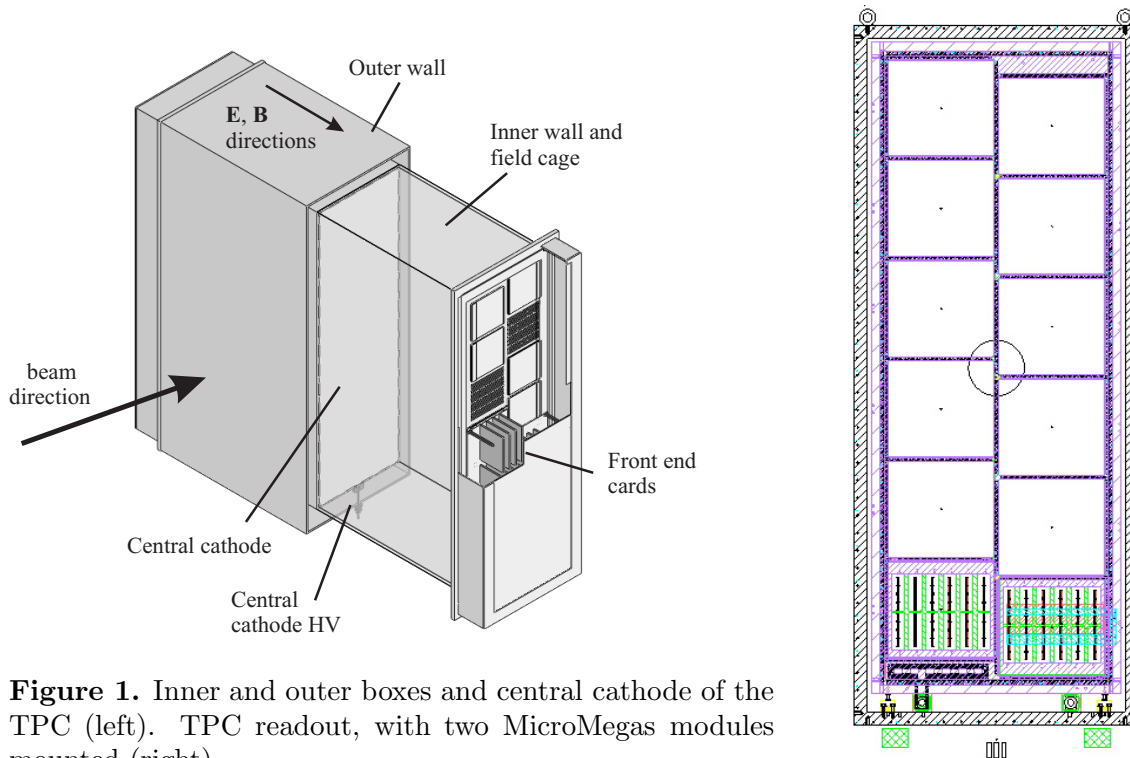

Figure 1. Inner and outer boxes and central cathode of the TPC (left). TPC readout, with two MicroMegas modules mounted (right).

2. TPC readout

Each MicroMegas module carries 1726 pads (6.9×9.7 MicroMegas²), on 48 columns and 36 lines, and is readout by 6 front-end electronic cards (FEC's), each containing 4 AFTER ASIC chips designed at Saclay (see fig.1). There are 3 TPC's and therefore 6 readout planes of 12 MicroMegas modules each, for a total of 124 416 pads. A front-end mezzanine gathers and provides the interface to the FEC's, a data concentration card is installed on each readout plane, and finally the data reduction is performed by a merger PC for the 3 TPC's, which formats the data and links it to the ND280 DAQ. The high segmentation allows the best point-resolution possible given the diffusion in the gas, but to the cost of lots of electronics.

2.1. Need of pad-per-pad characterization.

There are two main sources for the degradation of the space resolution in a TPC: noisy or dead pads, as in that case the cluster fit has to include neighboring pads, and cross-talk, which usually generates a delayed signal and causes a smearing of the signal, decreasing the number of points in a track. This affects the tracking efficiency, and the momentum and energy resolution. For example, the nominal 99% tracking efficiency of the HARP TPC was reduced to 92-96% because of faulty pads [2]. Note that the latest MicroMegas prototype built for T2K in the fall of 2006 presented no faulty pad at the end of the fabrication process.

2.2. MicroMegas principle.

The charges left by the ionization along the track of a particle crossing the TPC drift towards the central cathode and the anode (see fig.2). An avalanche is produced between the micromesh, supported 50-100 μm above the anode by short cylindrical pillars, and the anode. The time structure of the signal is shown on the right-hand side of the padplane in fig.2. In the case of the T2K ND280 TPC, the baseline for the drift field is 200 V/cm, and the MicroMegas amplification

gap will be set to a value of the order of -360 V over $128 \mu\text{m}$. Thanks to the funnel-shaped field lines configuration, almost 100% electron collection efficiency is achieved, provided the field ratio between the two regions is large enough and the mesh thin enough. For mesh pitches less than 20-50 microns, the extension of the avalanche is as large as the inter-hole space, forcing most of the ions to drift back on the mesh instead of drifting back into the TPC. This reduction of the ion backflow is very important for avoiding distortions due to ion space charge in a TPC [5].

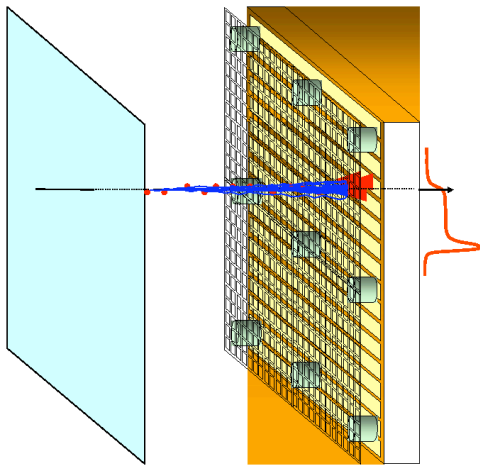

Figure 2. Left: schematic view of a MicroMegas. Note that the anode corresponds to the padplane in our case.

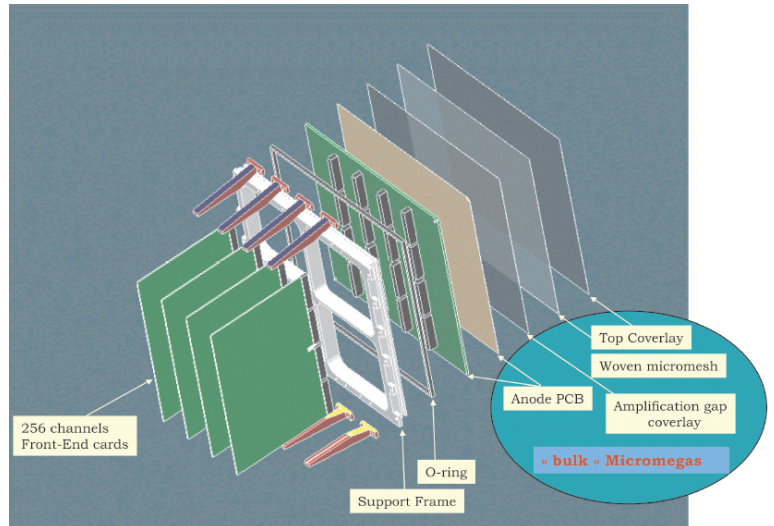

Figure 3. Exploded conceptual 3D view of a MicroMegas Module. The actual module will be equipped with 6 x 288 channels Front-End cards.

Figure 2 shows a T2K MicroMegas module, which consists in a bulk MicroMegas detector glued on a mechanical support frame (the stiffener) which assures the rigidity of the structure. The bulk MicroMegas uses the same principle as the usual MicroMegas, but the fabrication is simpler and more robust, allowing large areas to be produced and several cleanings to be performed during the process. The mesh, made out of 2 perpendicular layers of stainless-steel $19 \mu\text{m}$ wires 24 MicroMegas apart, is sandwiched between layers of insulating material; the sandwich is then etched, yielding 12 spacers per pad between the mesh and the padplane. The pads are electrically connected by vias in the padplane circuit board (PCB) inner layer to the connectors, soldered on the back side of the detector. A corner of the PCB is used to connect the micromesh to the high voltage supply from the backside of the detector.

3. Test-bench

The T2K ND280 TPC calibration program is divided following the 3 main steps of the detection process: the electron transportation in the gas, their detection by the MicroMegas, and finally the digitization of the signal. The two last items are addressed by the test-bench, which is responsible for providing the absolute energy scale of the signals detected by the TPC. For that, each MicroMegas will be put in a gas box reproducing the conditions of the TPC, a ^{55}Fe X-ray source will scan the padplane, and the following measurements will be performed:

- To detect inhomogeneities, a very precise collimation of the source is used to produce a **gain map**. A larger collimation is used to measure the absolute gain, from which the pad response function will be obtained.

- The **energy resolution** and **absolute energy calibration** are obtained from the reconstruction of the ^{55}Fe spectrum.
- The **local charge collection** is measured to study border effects.
- The **cross-talk** is characterized by scanning from one pad to the other with a collimation producing an illuminated spot smaller than the surface of a pad.

The test-bench also allows to measure the pulse shape (FWMH, rise time), the high-voltage (HV) stability and spark rate, the performance with different types of gas, the effect of the variation of the pressure and temperature on the gain, and different DAQ designs can be tested on this little mockup of the final TPC. On longer term, the degradation of the gain as a function of time can be studied.

3.1. Description.

The test-bench has been constructed at the Université de Genève, where the characterization of a 3 GEM tower [7] is presently being performed. It will be moved to CERN to be part of the MicroMegas production chain. Fig. 4 shows a general view of the setup. The module is held vertically inside a $61.6 \times 44.4 \times 7.5 \text{ cm}^3$ (20.5L) gas box, made out of G-10 and plexiglas (only G-10 for the final version), which is operated as a small drift chamber. It is closed by the padplane on one side, and by the cathode (an aluminized mylar sheet) supported by a grid on the other. It is mounted on a rail which allows to move it to the desired distance from the collimation tube holding the ^{55}Fe source, fixed on a set of two mechanical arms (X-Y stages), which move the source for the scanning of the pads. The readout cards are connected vertically on the padplane for a better ventilation.

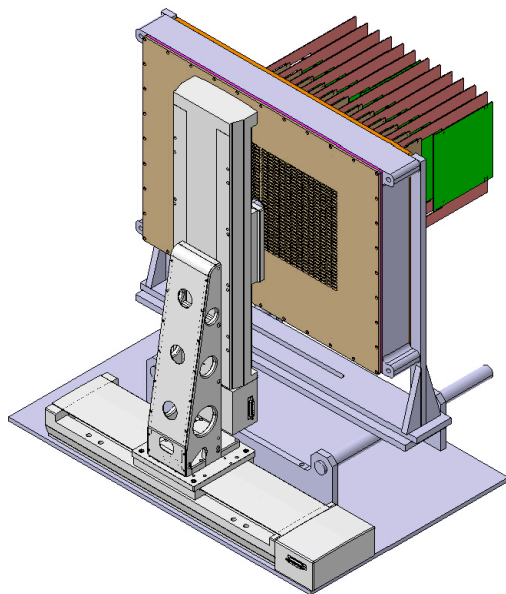

Figure 4. 3D view of the test-bench.

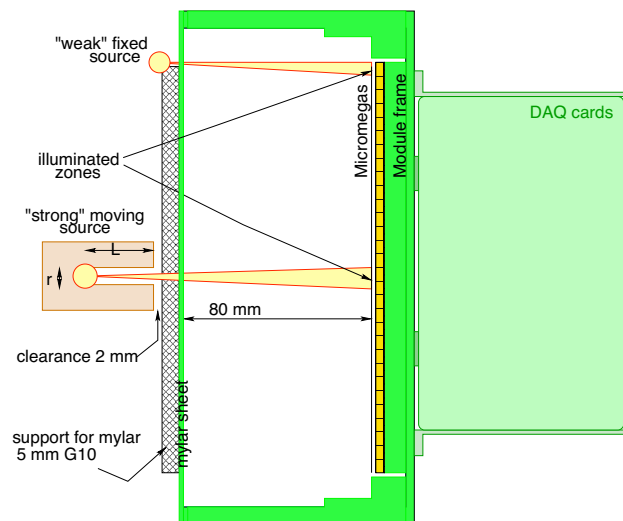

Figure 5. Side-view showing the moving collimated ^{55}Fe source, the two weaker sources fixed in the grid, and the corresponding illumination spots on the MicroMegas.

The gas box is also used for transporting the module from the assembly point to the test bench. It is operated with premix Ar:CO₂ (90:10) for the GEM, Ar:CF₄:C₄H₁₀ (95:3:2) for the T2K MicroMegas modules (CF₄ might be replaced by CO₂ in the final design). The drift space is 7.26 cm for the first version of the gas box, but will be reduced to 4 cm in the final version.

The grid ensures the flatness of the cathode, for drift field uniformity, provides HV protection for users, but it shadows the padplane from the source. The pattern of the grid is therefore out of phase with the pad alignment, in such a way that the middle of the pads are illuminated, as well as at least 2 of their 4 borders with the neighboring pads.

DAQ. The final T2K DAQ is still being designed, therefore the DAQ used for the measurements done at CERN in 2006 has been recycled. Each GEM or MicroMegas module is readout by 6 sets of protection, inverter and ALTRO cards, the last containing 8 ALTRO chips developed for the ALICE TPC. The 6×128 channels are linked by a bus PCB and readout by a USB to FEC interface card. For the MicroMegas, the T2K electronics will be used as soon as it becomes available, but in the meantime, the ALTRO electronics will be adapted by joining the sets of protection, inverter and ALTRO cards 2 by 2, and using a total of 12 of them for a single MicroMegas.

^{55}Fe sources. Fig.5 shows a side-view of the sources, gas box, grid, and spots on the MicroMegas illuminated by the X-rays. The higher-activity moving source is held in an aluminum collimation tube, designed to produce a spot of 2.4 MicroMegas diameter on the first GEM or MicroMegas. Its activity was chosen to limit the duration of the measurement (less than 6h per module), to reduce the effects of any change in the atmospheric conditions (pressure and temperature). The duration of the illumination of the whole padplane (not taking into account the mechanical movement nor the DAQ) is of 6-12h with about 80 conversion electrons reaching the GEM or MicroMegas per second, giving plenty of statistics (10^3 counts on one pad) to reconstruct the 5.9 keV peak. The 185 MBq source yields an effective activity (defined in the equation below) on the MicroMegas padplane of 79.7 kBq (more in the final design).

$$\begin{aligned} \text{effective activity} &= \text{nominal activity} \times 27.8\% \text{ branching ratio} \times \text{solid angle (collimation)} \\ &\times \text{absorption (air + cathode)} \times \text{fraction of conversion in Ar} \end{aligned}$$

Since the gain is very sensitive to variations in temperature, pressure and high voltage, and because the measurement will last for several hours, it is necessary to monitor the gain over time. This is accomplished by two ^{55}Fe sources, of weaker activity than the main one, illuminating a few pads permanently. If the variations of the gain on those pads are bigger than statistical fluctuations, hopefully it can be correlated to temperature and pressure changes, and therefore corrected for.

In order to monitor the gain stability, the pressure and temperature are monitored at all time, and two 3.7 MBq sources are inserted in two corners of the grid. The X-rays propagate through a hole providing a slight collimation to limit the number of illuminated pads. The spot spans 51 MicroMegas of the padplane, or 3 pads in the case of the GEM and 4 pads for the MicroMegas, with an effective activity of 1.03 MBq.

Gas system. The gas system shown in fig.6 is designed to provide a 10 mbar over pressure inside the gas box, to avoid ingress of O_2 , and to adapt to the atmospheric pressure. It contains flowmeters and bubblers at the input, and a pressure transmitter and bubbler at the exit. The gas box can be isolated from the system, allowing to transport the modules in a gas environment.

Simulations with Garfield and Maxwell [8] showed that the electric field lines are very uniform: less than 1% deviation on the first row of pads (check).

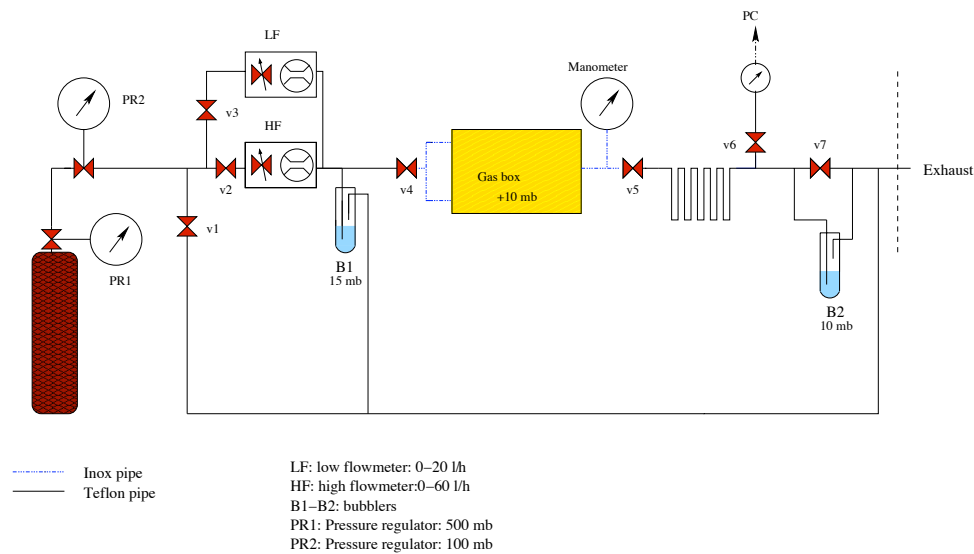

Figure 6. Gas system for the test-bench.

4. Status and future

5 bulk MicroMegas (1024 pads, $26 \times 27 \text{ cm}^2$) were built successfully for T2K in 2005, and 3 others (1726 pads, $34 \times 36 \text{ cm}^2$) were built in 2006, the third showing no faulty pads. 72 such modules have to be built for the T2K ND280 TPC readout, and all will be tested with the test-bench. The test-bench is an important part of the T2K ND280 TPC calibration program. The construction was completed in December 2006, a GEM module is presently being tested on the test-bench at the Université de Genève. The measurements with MicroMegas modules should start in the beginning of February 2007.

References

- [1] T.Lux, *A TPC for the near detector at T2K* in the same publication.
- [2] S. Borghi *Hadron production cross section measurement with the HARP large angle detectors*, thèse de doctorat, Université de Genève.
- [3] G. Charpak, I. Giomataris, Ph. Rebougeard and J.P. Robert, NIM A376, 29 (1996)
- [4] A. Delbart, R. De Oliveira and J-L. Ritou, "Production process of a "bulk" MicroMegas for the T2K-TPC", CEA-Saclay/DAPNIA/T2K-TPC internal note EDMS6234, 12/16/2005.
- [5] P. Colas, I. Giomataris and V. Lepeltier, NIM A 535, 226 (2004).
- [6] I.Giomataris et al., NIM A 560, 2 (2006).
- [7] E. Radicioni et al *A GEM based TPC with two large 3-GEM Towers*, IEEE
- [8] R. Veenhof *Garfield - simulation of gaseous detectors - Users Guide v.8.01*, CERN writeups, ref. W5050 (2005)